

The Development 05

- The Penthouse* 27
- The Specification* 33
- The Restaurant* 39
- The Plans & Specifications* 45
- Sustainability* 86

Westminster Fire Station: a Grade II listed Edwardian gem, *thoughtfully reimaged* as a collection of 17 beautiful boutique apartments. Here, classical London architecture is juxtaposed with an exceptional contemporary new build, creating remarkable homes of *distinction*.

In the heart of Victoria, amid many of London's most iconic attractions, the original Fire Station is entering a new phase of its existence, joined by a modern building — *The Station House*. Private residences and an intimate restaurant now frame the peaceful courtyard, where the station's engines and horses once resided.

While *unmistakably contemporary*, the design of the apartments also draws inspiration from the building's past. History is everywhere: in the glazed bricks, parquet flooring, original fireman's pole, and the horizontal banding on the external architecture. Refined in every detail, this is a *masterful reinvention* of a London institution.

From Autumn 2021, *Westminster Fire Station* will herald a stylish new chapter in the metropolitan life of Victoria.



GREYHOUND
PLACE SW1

RESTAURANT

FIRE BRIGADE
STATION
WESTMINSTER







Images are computer generated, indicative only and subject to change.

London life can be exhilarating, so a peaceful retreat is always welcome. The inner courtyard at *Westminster Fire Station* has been sensitively redesigned as a secluded green space, where carefully selected plants breathe new life into the atmosphere. A gentle fountain adds to the natural sense of calm, completing a scene of *tranquillity* visible from almost every apartment.



Images are computer generated, indicative only and subject to change.

A tale of two houses

A peaceful courtyard links the original Fire Station with the newly built Station House – a perfect marriage of history and modernity, with the intention of a union meant to last.

On one side, a building that has stood for a century, now optimised to improve its energy performance. On the other, a new build, designed with high-quality, low-impact materials to help further reduce carbon emissions.

Read more detail about the sustainability of the buildings on page 86.



Courtyard designed by James Lee Landscape Design

Images are computer generated, indicative only and subject to change.

The Lobby

Arriving at *Westminster Fire Station* is a *welcoming* experience. The striking façade, with its bold pattern of red brick, horizontal banding of Portland stone, and restored carriage doors, announces the building's heritage with poise.

You enter through the engine doors, to be greeted by the apartments' *dedicated concierge*. Beyond, you find the courtyard, an oasis of leafy tranquillity nestled between The Fire Station, a historical building, and The Station House, a newly built building.

Throughout the buildings, new and old sit together harmoniously. The Station House façade, with its rows of iridescent bricks, is a modern reinterpretation of the original Station's Edwardian architectural detailing. Custom-brass screens, inspired by the building's cast iron features, adorn both The Fire Station and The Station House.



Images are computer generated, indicative only and subject to change.



Images are computer generated, indicative only and subject to change.

The Apartments

Each apartment at *Westminster Fire Station* – six in The Fire Station, 11 in The Station House – has its own charming character and compelling layout. All 17 share exceptional *attention to detail* and seamless integration of historic and contemporary elements.

Italian marbles mix with hand-glazed ceramics, with un-lacquered brass accents throughout. Engineered oak herringbone parquet in the living spaces replicates the original flooring. Many features are custom designed, such as bespoke European oak and brass ironmongery, kitchen cupboards with brass detailing, and tile flooring in a woven mosaic pattern.

Bedrooms in The Fire Station

*Natural wood floors
flow through into
the bedrooms, where
underfloor heating
keeps everything cosy
in the winter months.*



Images are computer generated, indicative only and subject to change.



Family bathrooms

Italian marble floor tiles, with characteristic swirls and veins, and wall tiles laid in a herringbone pattern, lend the bathrooms a timeless quality. Accents of gold – including antique brassware – catch the eye.

Images are computer generated, indicative only and subject to change.

The Station House apartments

Light floods in through floor-to-ceiling windows, illuminating the clean lines and elegance of the architecture. Sliding doors with bespoke bronze screening lead onto a private terrace, the ideal setting for al-fresco summer dining.



Images are computer generated, indicative only and subject to change.



Images are computer generated, indicative only and subject to change.

Master bathrooms

Three types of marble make up the bespoke tile floor, designed to be a pattern reminiscent of woven fire hoses. White marble walls allow the antique gold brassware to contrast, creating an elegant balance of traditional and modern interiors.

The Penthouse

The Fire Station penthouse

The sun-drenched penthouse kitchen is filled with charming architectural features and finishes.

The circular window creates a unique focal point with a view of Westminster, the Shard and Big Ben. Additional light spills in through skylights above. The pitched roof creates more volume allowing the area to also be an entertaining space.



Images are computer generated, indicative only and subject to change.



Images are computer generated, indicative only and subject to change.



Images are computer generated, indicative only and subject to change.

Loft bathroom in The Fire Station penthouse

A secret hideaway tucked away in the eaves of the penthouse provide a bit of respite from city living. Designed to be luxurious and calming, shiplap clad walls and intricately veined marble draw the eye to the elegant free-standing bath, the focal point of the room.

The Materials

- 1 *Hand-cut enameled Moroccan tile*
- 2 *Limestone*
- 3 *Terracotta*
- 4 *Italian marble*
- 5 *Italian marble*
- 6 *Engineered oak parquet*
- 7 *Terrazzo*
- 8 *Sandstone*
- 9 *Natural quartzite*

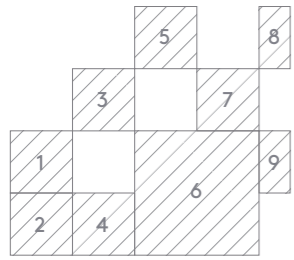

Materials are for indicative purposes only



The details

*Custom-designed ironmongery
with brass rose and European oak
wood handles.*

The Restaurant



Images are computer generated, indicative only and subject to change.

Mathura by Atul Kochhar

Entering through the original carriage doors of the fire engine bays, you discover “Mathura” – the new restaurant from pioneering and twice Michelin-starred chef Atul Kochhar.

Mathura is the culinary culmination of Kochhar’s travels around India, Pakistan, and Afghanistan. The restaurant showcases the renowned chef’s signature Indian flair and love of locally grown British produce, while bringing unexpected twists to excite and delight diners.



Spread over two floors, the dining rooms and bar are equally as dramatic as the food. Many original features have been retained, including the glazed tiled brick walls, steel beams across the four-metre-high ceilings, and the fireman's pole. But perhaps most special of all is the original Watch Room – a feature rarely retained in fire station redevelopments – which has been protected and repurposed as a private dining space.

Mathura offers a unique dining experience to drink in the atmosphere and explore new fusions of flavour in a historic ambience.

The plans and specifications

Masterplan, overhead and section diagrams of The Fire Station and The Station House

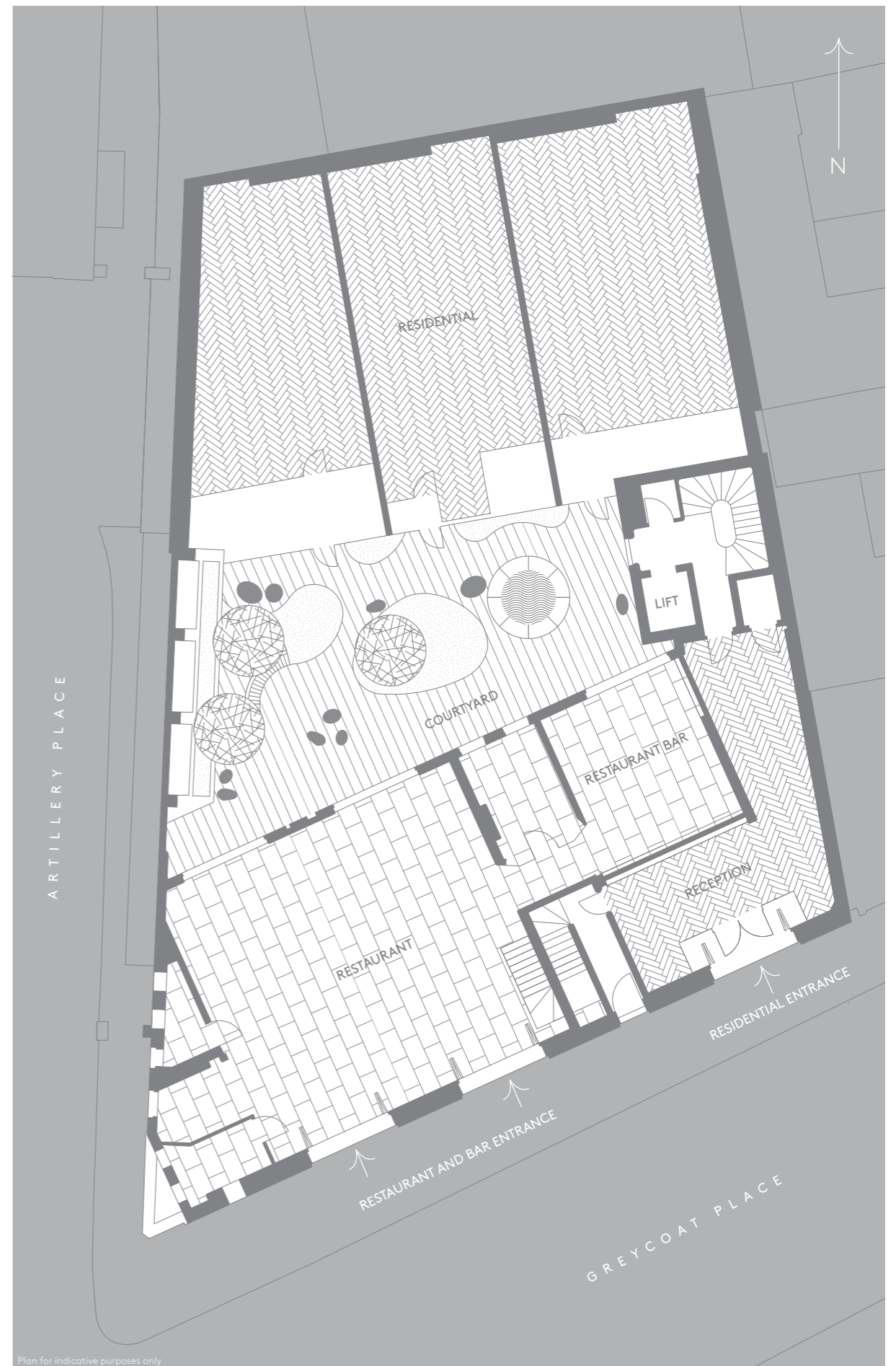
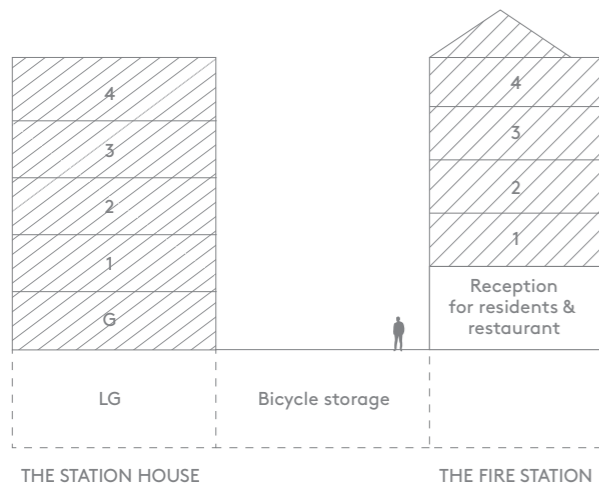

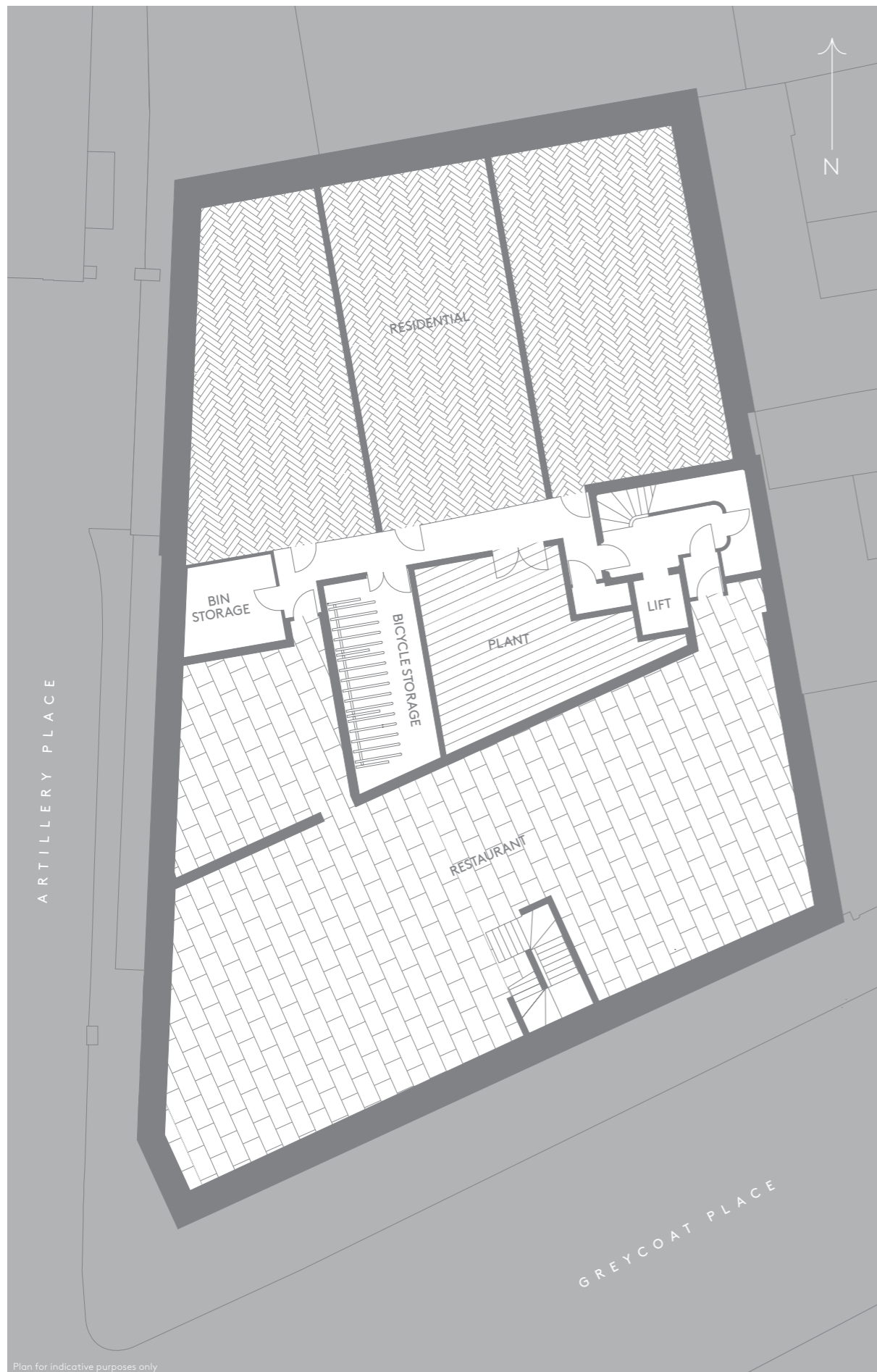

Plan for indicative purposes only

Basement plan and the general specification

Heating & cooling

- Underfloor heating throughout occupied areas of the apartments
- Comfort cooling in the living rooms and principle bedrooms of all apartments
- Wall mounted controllers, app-controlled comfort cooling and web based heating controls are provided

Lighting & electrical fittings

- Dimmable LED recessed downlights and pendants throughout
- Under-cabinet lighting in kitchens
- Designer sockets and switches
- Fiber-optic cabling for high-speed internet
- Wiring for Sky Q

Security

- Videophone entry
- Banham deadlock and deadbolt locking system*
- CCTV in bin and bicycle stores
- Access control

Amenities

- Concierge
- Private courtyard
- Restaurant (open to the general public)
- Bicycle storage
- Zip Car club membership (10 years) & Westminster City Council Resident Parking Permit eligibility

* except Apartment 8, 9, 10 and 19 which have Schuco doors.

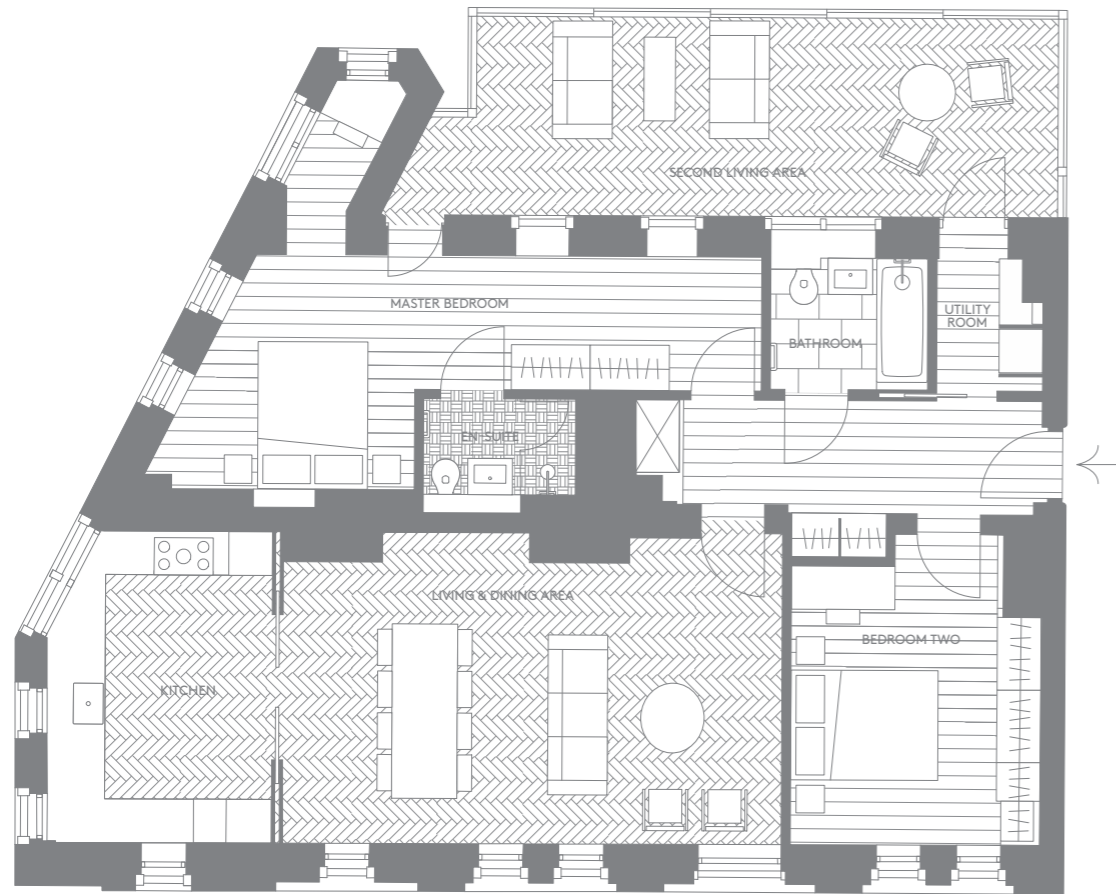

THE FIRE STATION
 Apartment 1, first floor
Two bedrooms

Internal area	134 sq m	1439 sq ft
Living & dining area	7.0 x 4.3m	23.0 x 14.1ft
Kitchen	3.1 x 4.3m	10.2 x 14.1ft
Master bedroom	7.9 x 5.6m	25.9 x 18.4ft*
Bedroom two	3.3 x 4.3m	10.8 x 14.1ft
Second living area	9.3 x 2.7m	30.5 x 8.9ft

*Includes dressing area and study niche

Floor areas are approximate.
 Plans and specifications are for indicative purposes only.

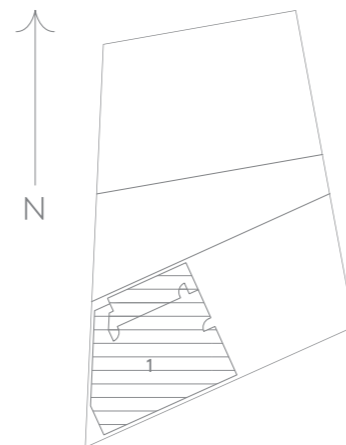

- Kitchen**
- Kitchen cabinetry and hardware custom-designed and unique to the development
 - Quartzite natural stone worktop
 - Mirrored backsplash with a bronze tint
 - Cooker hood in antique brass
 - White ceramic under-mount sink
 - Designer single lever tap
 - Siemens dishwasher
 - Liebherr fridge freezer
 - Miele induction hob
 - Miele PureLine microwave/oven combi
 - Miele PureLine single oven

- Interior finishes**
- Engineered oak parquet flooring in a herringbone pattern to living, kitchen and dining areas
 - Engineered oak plank flooring laid in bedrooms and hall
 - Custom-designed, integrated wardrobes to all bedrooms
 - Siemens washing machine and separate condenser dryer
 - Custom-designed ironmongery with brass rose and European oak wood handle

- Bathrooms**
- Bathroom tiling: Calacatta Viola marble flooring and white matt ceramic wall tile laid in a herringbone pattern with tile skirting boards
 - Bathroom fittings: ceramic pedestal basin, antique gold basin tap, wall-mounted mirror cabinet with lighting, antique gold towel warmer, classic back-to-wall toilet and inset bath with antique gold shower and bath fixtures
 - Master en-suite tiling: custom-designed marble flooring in a mosaic pattern and white marble walls
 - Master en-suite fittings: ceramic basin on antique gold console, antique gold tap, wall-mounted mirror cabinet with lighting, antique gold towel warmer, back-to-wall toilet and shower with antique gold fixtures

THE FIRE STATION
 Apartment 2, first floor
Two bedrooms

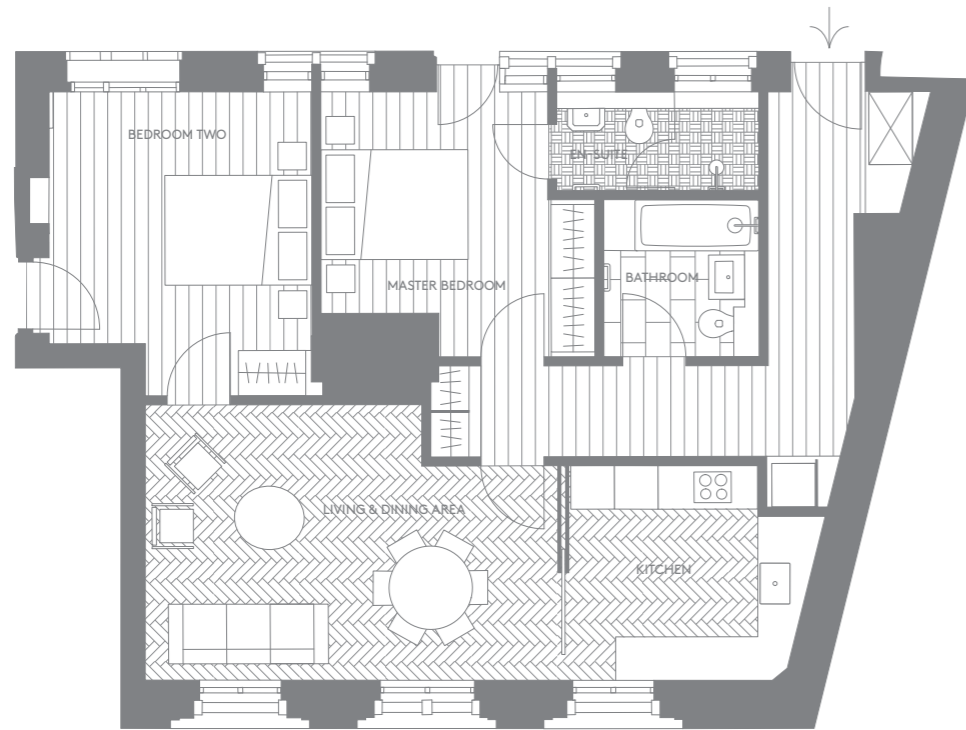

Internal area	84 sq m	902 sq ft
Living & dining area	5.7 x 3.8m	18.7 x 12.5ft
Kitchen	3.5 x 3.0m	11.5 x 9.8ft
Master bedroom	3.8 x 3.6m	12.5 x 11.8ft
Bedroom two	3.9 x 4.2m	12.8 x 13.8ft

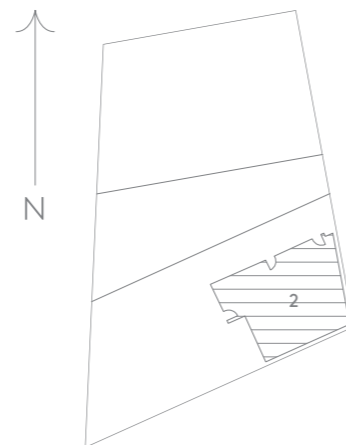

Floor areas are approximate.
 Plans and specifications are for indicative purposes only.

- Kitchen**
- Kitchen cabinetry and hardware custom-designed and unique to the development
 - Quartzite natural stone worktop
 - Mirrored backsplash with a bronze tint
 - Cooker hood in antique brass
 - White ceramic under-mount sink
 - Designer single lever tap
 - Siemens dishwasher
 - Liebherr fridge freezer
 - Miele induction hob
 - Miele PureLine microwave/oven combi
 - Miele PureLine single oven

- Interior finishes**
- Engineered oak parquet flooring in a herringbone pattern to living, kitchen and dining areas
 - Engineered oak plank flooring laid in bedrooms and hall
 - Custom-designed, integrated wardrobes to all bedrooms
 - Siemens washing machine and separate condenser dryer
 - Custom-designed ironmongery with brass rose and European oak wood handle

- Bathrooms**
- Bathroom tiling: Calacatta Viola marble flooring and white matt ceramic wall tile laid in a herringbone pattern with tile skirting boards
 - Bathroom fittings: ceramic pedestal basin, antique gold basin tap, bespoke mirror cabinet with lighting, antique gold towel warmer, classic back-to-wall toilet and inset bath with antique gold shower and bath fixtures
 - Master en-suite tiling: custom-designed marble flooring in a mosaic pattern and white marble walls
 - Master en-suite fittings: ceramic basin on antique gold console, antique gold basin tap, wall-mounted mirror cabinet with lighting, antique gold towel warmer, classic back-to-wall toilet and shower with antique gold fixtures

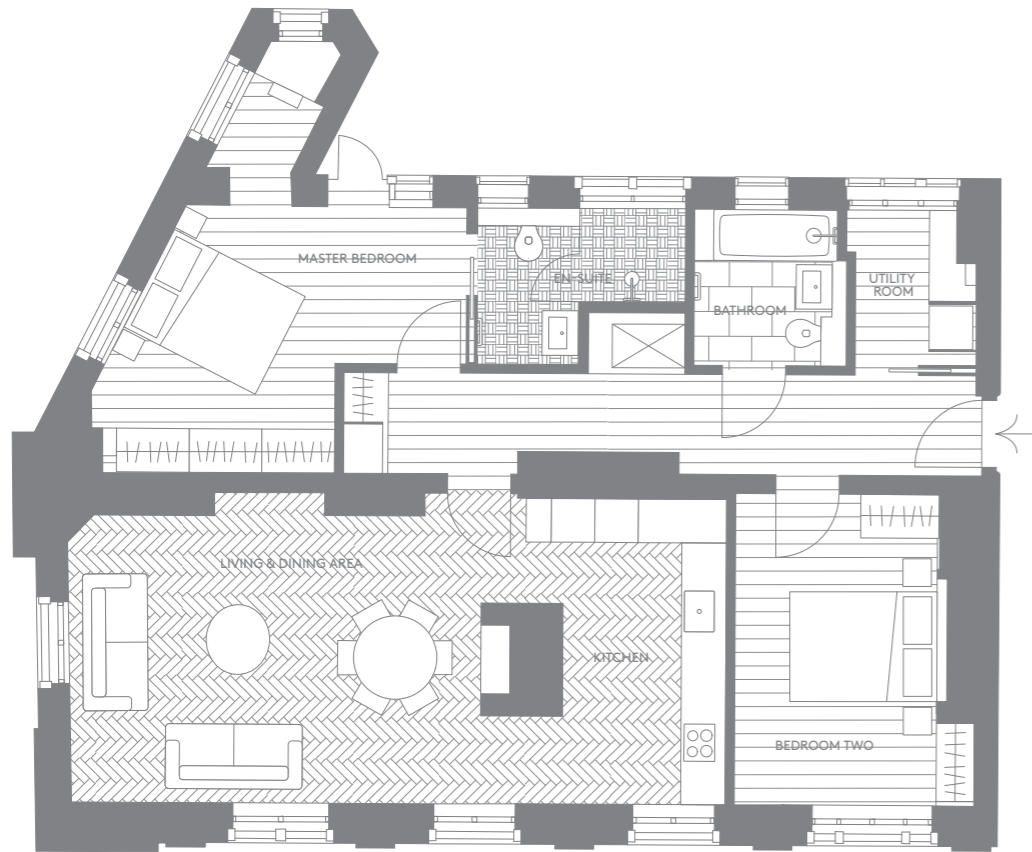

THE FIRE STATION
 Apartment 3, second floor
Two bedrooms

Internal area	100 sq m	1077 sq ft
Living & dining area	6.2 x 4.3m	20.3 x 14.1ft
Kitchen	2.9 x 4.2m	9.5 x 13.8ft
Master bedroom	4.9 x 5.9m	16.1 x 19.4ft*
Bedroom two	3.3 x 4.3m	10.8 x 14.1ft

*Includes dressing area and study niche

Floor areas are approximate.
 Plans and specifications are for indicative purposes only.

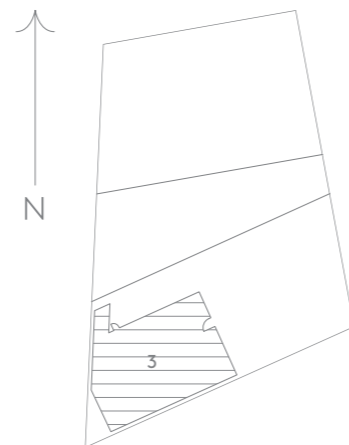

- Kitchen**
- Kitchen cabinetry and hardware custom-designed and unique to the development
 - Quartzite natural stone worktop
 - Mirrored backsplash with a bronze tint
 - White ceramic under-mount sink
 - Designer single lever tap
 - Siemens dishwasher
 - Liebherr fridge freezer
 - Miele induction hob
 - Miele PureLine microwave/oven combi
 - Miele PureLine single oven

- Interior finishes**
- Engineered oak parquet flooring in a herringbone pattern to living, kitchen and dining areas
 - Engineered oak plank flooring laid in bedrooms, and hall
 - Custom-designed, integrated wardrobes to all bedrooms
 - Siemens washing machine and separate condenser dryer
 - Custom-designed ironmongery with brass rose and European oak wood handle

- Bathrooms**
- Bathroom tiling: Calacatta Viola marble flooring and white matt ceramic wall tile laid in a herringbone pattern with tile skirting boards
 - Bathroom fittings: ceramic pedestal basin, antique gold basin tap, wall-mounted mirror cabinet with lighting, antique gold towel warmer, classic back-to-wall toilet and inset bath with antique gold shower and bath fixtures
 - Master en-suite tiling: custom-designed marble flooring in a mosaic pattern and white marble walls
 - Master en-suite fittings: ceramic basin on antique gold console, antique gold basin tap, wall-mounted mirror cabinet with lighting, antique gold towel warmer, classic back-to-wall toilet and shower with antique gold fixtures

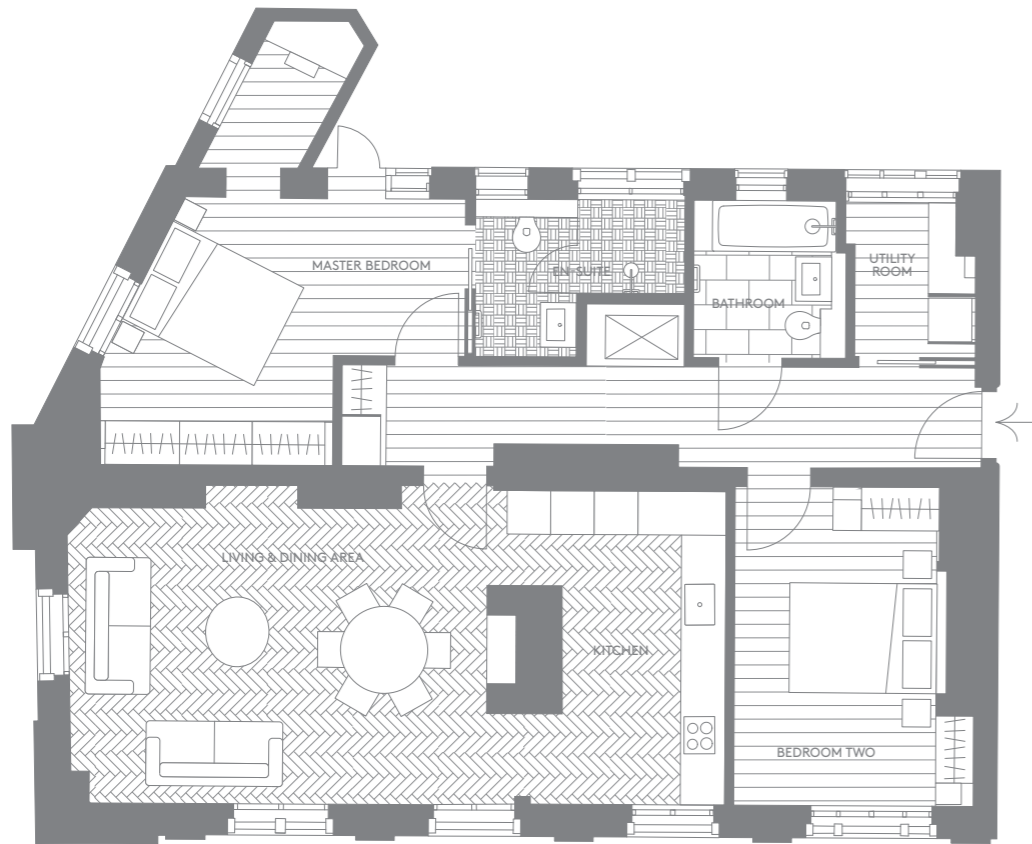

THE FIRE STATION
 Apartment 4, third floor
Two bedrooms

Internal area	102 sq m	1100 sq ft
Living & dining area	5.9 x 4.4 m	19.4 x 14.4ft
Kitchen	3.2 x 4.3 m	10.5 x 14.1ft
Master bedroom	5.0 x 6.1 m	16.4 x 20.0ft*
Bedroom two	3.3 x 4.4 m	10.8 x 14.4ft

*Includes dressing area and study niche

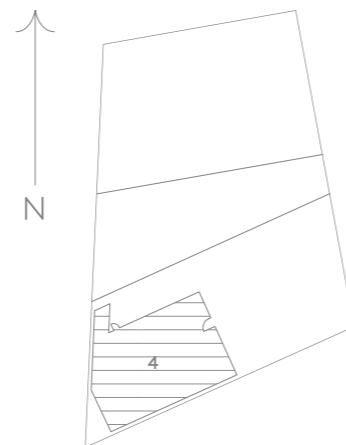

Floor areas are approximate.
 Plans and specifications are for indicative purposes only.

- Kitchen**
- Kitchen cabinetry and hardware custom-designed and unique to the development
 - Quartzite natural stone worktop
 - Mirrored backsplash with a bronze tint
 - White ceramic under-mount sink
 - Designer single lever tap
 - Siemens dishwasher
 - Liebherr fridge freezer
 - Miele induction hob
 - Miele PureLine microwave/oven combi
 - Miele PureLine single oven

- Interior finishes**
- Engineered oak parquet flooring in a herringbone pattern to living, kitchen and dining areas
 - Engineered oak plank flooring laid in bedrooms, and hall
 - Custom-designed, integrated wardrobes to all bedrooms
 - Siemens washing machine and separate condenser dryer
 - Custom-designed ironmongery with brass rose and European oak wood handle

- Bathrooms**
- Bathroom tiling: Calacatta Viola marble flooring and white matt ceramic wall tile laid in a herringbone pattern with tile skirting boards
 - Bathroom fittings: ceramic pedestal basin, antique gold basin tap, wall-mounted mirror cabinet with lighting, antique gold towel warmer, classic back-to-wall toilet and inset bath with antique gold shower and bath fixtures
 - Master en-suite tiling: custom-designed marble flooring in a mosaic pattern and white marble walls
 - Master en-suite fittings: ceramic basin on antique gold console, antique gold basin tap, wall-mounted mirror cabinet with lighting, antique gold towel warmer, classic back-to-wall toilet and shower with antique gold fixtures

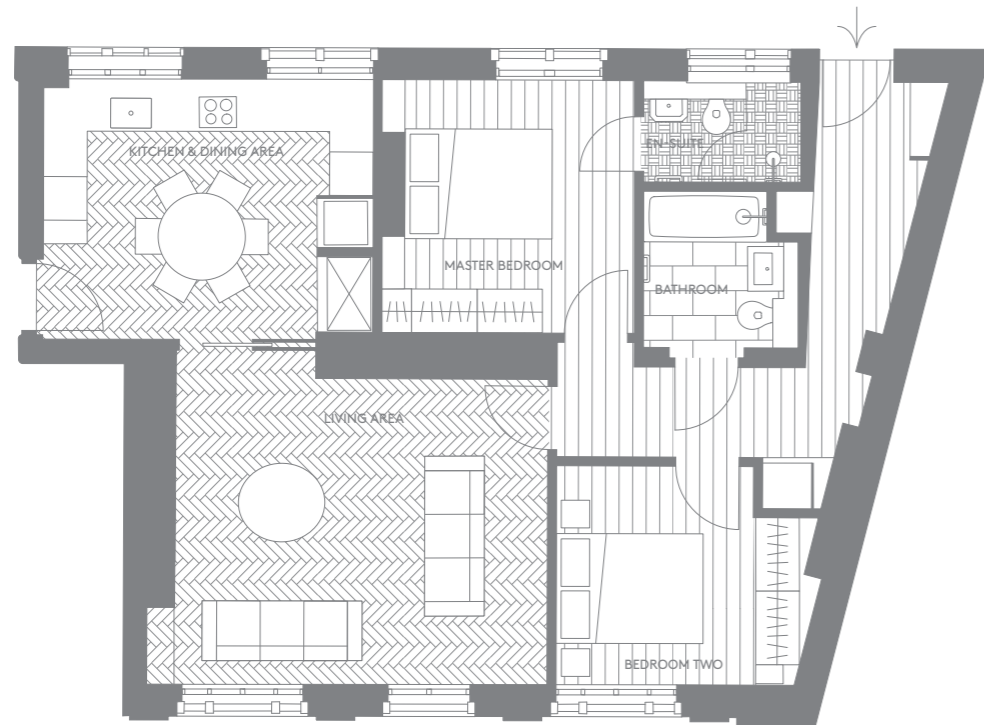

THE FIRE STATION
 Apartment 6, third floor
Two bedrooms

Internal area	87 sq m	935 sq ft
Kitchen & dining area	4.5 x 3.6m	14.8 x 11.8ft
Living area	5.5 x 4.6m	18.0 x 15.1ft
Master bedroom	3.5 x 3.5m	11.5 x 11.5ft
Bedroom two	3.7 x 3.0m	12.1 x 9.8ft

Floor areas are approximate.
 Plans and specifications are for indicative purposes only.

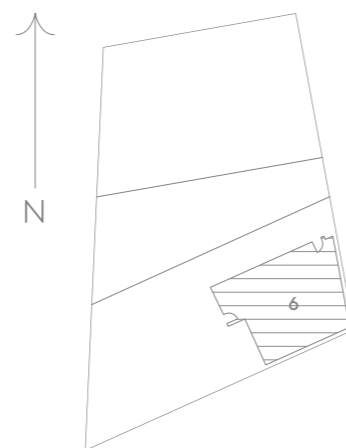

- Kitchen**
- Kitchen cabinetry and hardware custom-designed and unique to the development
 - Quartzite natural stone worktop
 - Mirrored backsplash with a bronze tint
 - White ceramic under-mount sink
 - Designer single lever tap
 - Siemens dishwasher
 - Liebherr fridge freezer
 - Miele induction hob
 - Miele PureLine microwave/oven combi
 - Miele PureLine single oven

- Interior finishes**
- Engineered oak parquet flooring in a herringbone pattern to living, kitchen and dining areas
 - Engineered oak plank flooring laid in bedrooms and hall
 - Custom-designed, integrated wardrobes to all bedrooms
 - Siemens washing machine and separate condenser dryer
 - Custom-designed ironmongery with brass rose and European oak wood handle

- Bathrooms**
- Bathroom tiling: Calacatta Viola marble flooring and white matt ceramic wall tile laid in a herringbone pattern with tile skirting boards
 - Bathroom fittings: ceramic pedestal basin, antique gold basin tap, wall-mounted mirror cabinet with lighting, antique gold towel warmer, classic back-to-wall toilet and inset bath with antique gold shower and bath fixtures
 - Master en-suite tiling: custom-designed marble flooring in a mosaic pattern and white marble walls
 - Master en-suite fittings: ceramic basin on antique gold console, antique gold basin tap, wall-mounted mirror cabinet with lighting, antique gold towel warmer, classic back-to-wall toilet and shower with antique gold fixtures



THE FIRE STATION
 Penthouse Apartment 7, fourth floor
Three bedrooms

- Kitchen**
- Kitchen cabinetry and hardware custom-designed and unique to the development
 - Quartzite natural stone worktop
 - Glazed terracotta backsplash
 - Cooker hood in antique brass
 - White ceramic under-mount sink
 - Designer single lever tap
 - Siemens dishwasher
 - Liebherr fridge freezer
 - Miele induction hob
 - Miele PureLine microwave/oven combi
 - Miele PureLine single oven
 - Miele warming drawer
 - Wine cooler

- Bathrooms**
- Bathroom tiling: Calacatta Viola marble flooring and white matt ceramic wall tile laid in a herringbone pattern with tile skirting boards
 - Bathroom fittings: ceramic pedestal basin, antique gold basin tap, wall-mounted mirror cabinet with lighting, antique gold towel warmer, classic back-to-wall toilet and inset bath with antique gold shower and bath fixture
 - Master en-suite tiling: custom-designed marble flooring in a mosaic pattern and bespoke wall cladding
 - Master en-suite fittings: ceramic basin on antique gold console, antique gold tap basin, bespoke mirror cabinet, antique gold towel warmer, classic back-to-wall toilet and free-standing bath with antique gold bath fixture

- Interior finishes**
- Engineered oak parquet flooring in a herringbone pattern to living, kitchen and dining areas
 - Engineered oak plank flooring laid in bedrooms, and hall
 - Custom-designed, integrated wardrobes to all bedrooms
 - Siemens washing machine and separate condenser dryer
 - Custom-designed ironmongery with brass rose and European oak wood handle
 - Bioethanol Fireplace

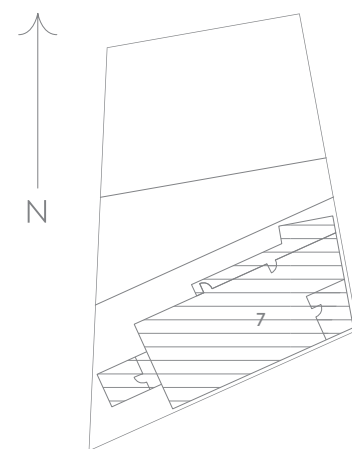

Internal area	159 sq m	1707 sq ft			
Fourth floor (bottom plan)			Fifth floor (top plan)		
Kitchen & dining area	9.8 x 3.6m	32.2 x 11.8ft	Bedroom three	6.0 x 3.3m	19.7 x 10.8ft
Living area	6.0 x 4.7 m	19.7 x 15.4ft			
Study	2.5 x 1.5 m	8.2 x 4.9ft			
Master bedroom	7.3 x 4.4 m	24.0 x 14.4ft			
Bedroom two	3.5 x 3.7 m	11.5 x 12.1ft			
Terrace one area	8.5 sq m	91.5 sq ft			
Terrace two area	20.8 sq m	223.9 sq ft			

Floor areas are approximate.
 Plans and specifications are for indicative purposes only.
 Dashed area indicate approximate skylight areas.

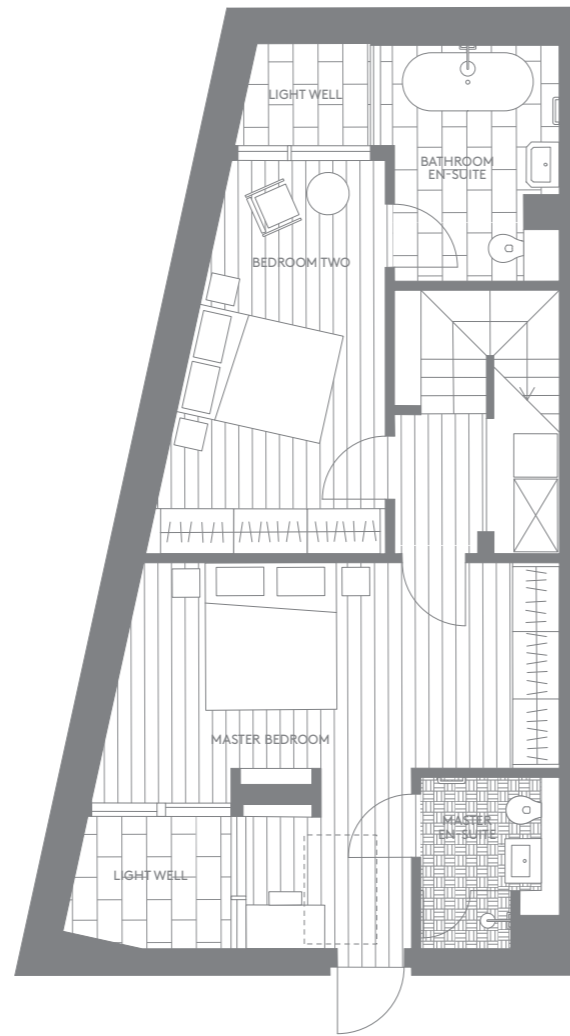
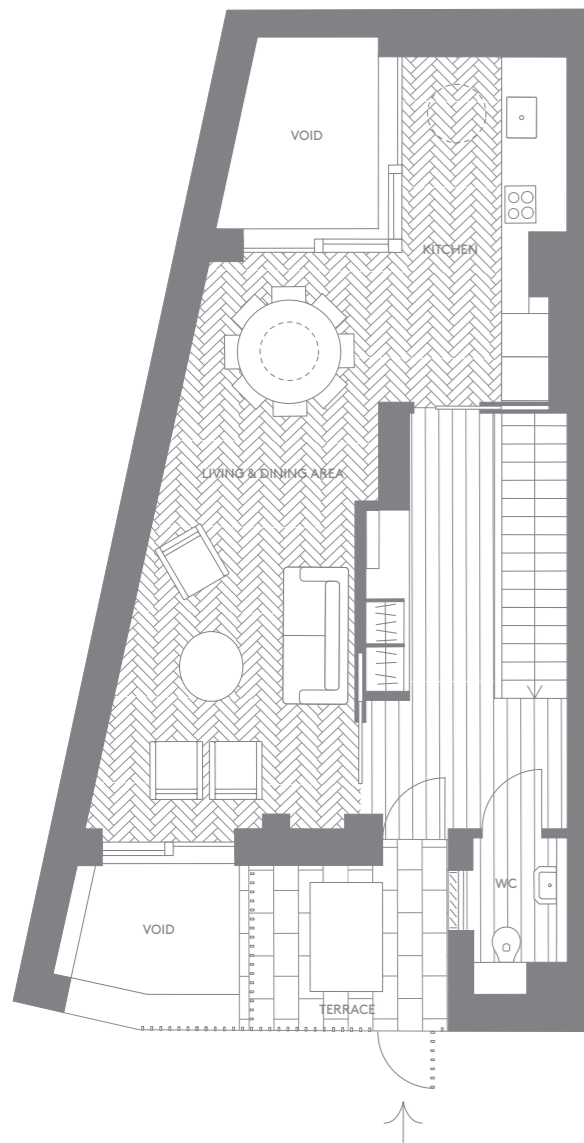

THE STATION HOUSE

Apartment 8, lower & ground floors

Two bedrooms

Internal area 118 sq m 1274 sq ft

Ground floor (left plan)

Living & dining area 3.7 x 7.9m 12.1 x 25.9ft
 Kitchen 2.3 x 4.8m 7.5 x 15.7ft
 Terrace area 6.3 sq m 67.4 sq ft

Lower ground floor (right plan)

Master bedroom 6.3 x 5.3m 20.7 x 17.4ft
 Bedroom two 3.3 x 5.4m 10.8 x 17.7ft
 Ceiling height up to 3.6m on lower floor

Floor areas are approximate.
 Plans and specifications are for indicative purposes only.
 Dashed area indicate approximate skylight areas.

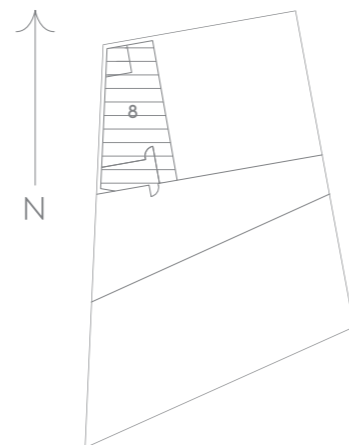

Kitchen

- Kitchen cabinetry and hardware custom-designed and unique to the development
- Quartzite natural stone worktop
- Mirrored backsplash with a bronze tint
- White ceramic under-mount sink
- Designer single lever tap
- Siemens dishwasher
- Liebherr fridge freezer
- Miele induction hob
- Miele PureLine microwave/oven combi
- Miele PureLine single oven

Interior finishes

- Engineered oak parquet flooring in a herringbone pattern to living, kitchen and dining areas
- Engineered oak plank flooring laid in bedrooms, hall and WC
- Custom-designed, integrated wardrobes to all bedrooms
- Siemens washing machine and separate condenser dryer
- Custom-designed ironmongery with brass rose and European oak wood handle

Bathrooms

- Bathroom en-suite tiling: Calacatta Viola marble flooring and white matt ceramic wall tile laid in a herringbone pattern with tile skirting boards
- Bathroom en-suite fittings: ceramic pedestal basin, antique gold basin tap, wall-mounted mirror cabinet with lighting, antique gold towel warmer, classic back-to-wall toilet and free-standing bath with antique gold shower and bath fixtures
- Master en-suite tiling: custom-designed marble flooring in a mosaic pattern and white marble walls
- Master en-suite fittings: ceramic basin on antique gold console, antique gold tap, wall-mounted mirror cabinet with lighting, antique gold towel warmer, classic back-to-wall toilet and shower with antique gold fixtures
- WC finish: engineered oak plank flooring and designer wallpaper
- WC fittings: ceramic basin on antique gold console, antique gold basin tap, wall-mounted mirror, classic back-to-wall toilet and decorative lighting

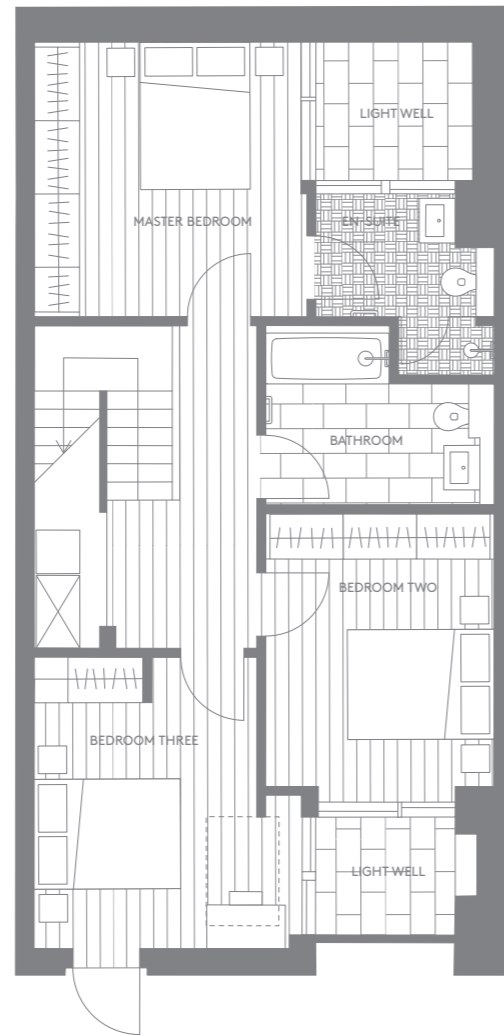
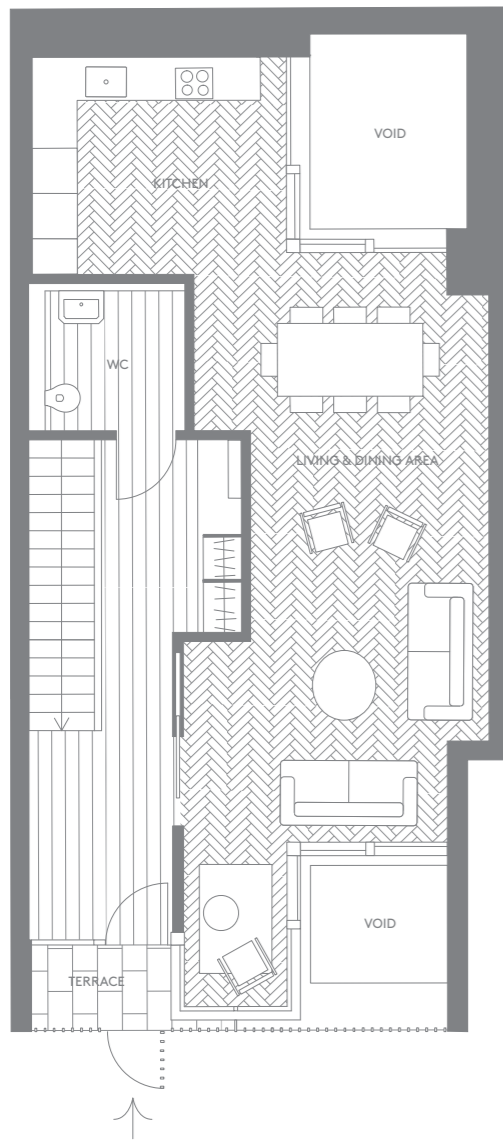

THE STATION HOUSE

Apartment 9, lower & ground floors

Three bedrooms

Internal area	137 sq m	1472 sq ft
Ground floor (left plan)		
Living & dining area	4.2 x 10.4m	13.8 x 34.1ft
Kitchen	3.5 x 3.0m	11.5 x 9.8ft
Terrace area	2.2 sq m	23.3 sq ft
Lower ground floor (right plan)		
Master bedroom	3.9 x 3.8m	12.8 x 12.3ft
Bedroom two	3.1 x 4.0m	10.2 x 13.1ft
Bedroom three	3.7 x 4.0m	12.1 x 13.1ft
Ceiling height up to 3.6m on lower floor		

Floor areas are approximate.
Plans and specifications are for indicative purposes only.
Dashed area indicate approximate skylight area.

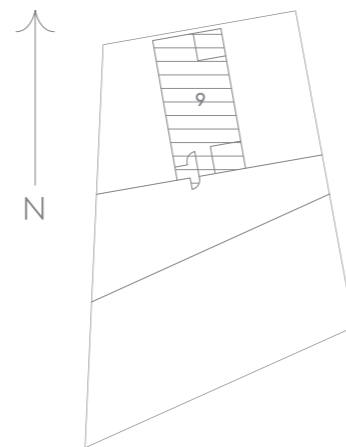

- Kitchen**
- Kitchen cabinetry and hardware custom-designed and unique to the development
 - Quartzite natural stone worktop
 - Mirrored backsplash with a bronze tint
 - White ceramic under-mount sink
 - Designer single lever tap
 - Siemens dishwasher
 - Liebherr fridge freezer
 - Miele induction hob
 - Miele PureLine microwave/oven combi
 - Miele PureLine single oven

- Interior finishes**
- Engineered oak parquet flooring in a herringbone pattern to living, kitchen and dining areas
 - Engineered oak plank flooring laid in bedrooms, hall and WC
 - Custom-designed, integrated wardrobes to all bedrooms
 - Siemens washing machine and separate condenser dryer
 - Custom-designed ironmongery with brass rose and European oak wood handle

- Bathrooms**
- Bathroom tiling: Calacatta Viola marble flooring and white matt ceramic wall tile laid in a herringbone pattern with tile skirting boards
 - Bathroom fittings: ceramic pedestal basin, antique gold basin tap, wall-mounted mirror cabinet with lighting, antique gold towel warmer, classic back-to-wall toilet and inset bath with antique gold shower and bath fixtures
 - Master en-suite tiling: custom-designed marble flooring in a mosaic pattern and white marble walls
 - Master en-suite fittings: ceramic basin on antique gold console, antique gold basin tap, wall-mounted mirror cabinet with lighting, antique gold towel warmer, classic back-to-wall toilet and shower with antique gold fixtures
 - WC finish: engineered oak plank flooring and designer wallpaper
 - WC fittings: ceramic basin on antique gold console, antique gold basin tap, wall-mounted mirror, classic back-to-wall toilet and decorative lighting

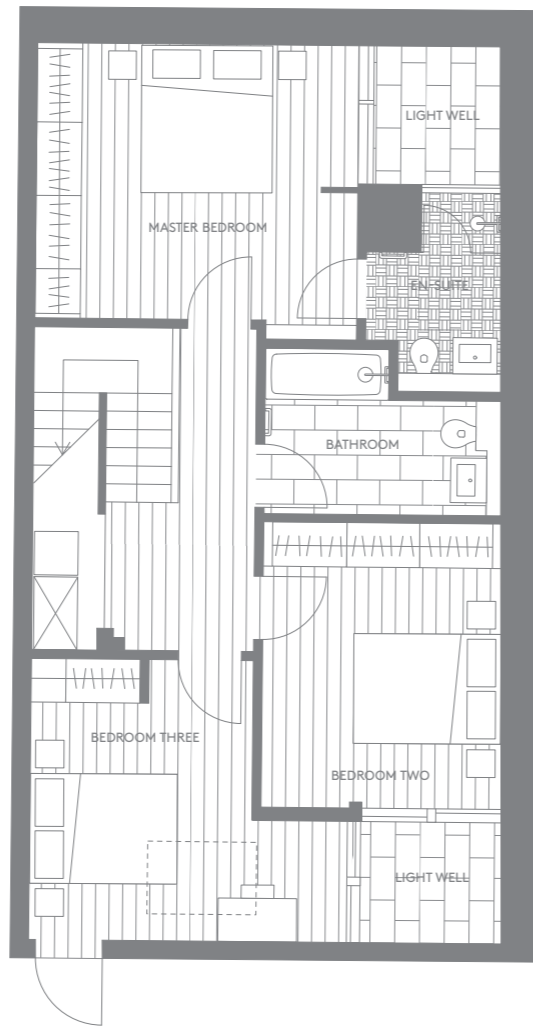
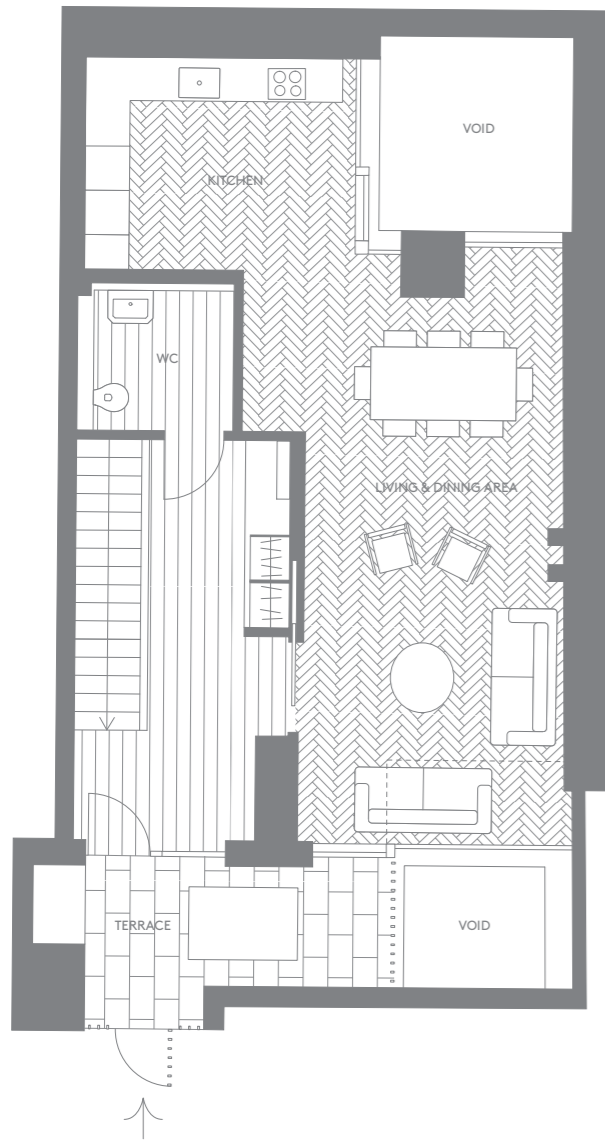

THE STATION HOUSE

Apartment 10, lower & ground floors

Three bedrooms

Internal area	138 sq m	1490 sq ft
Ground floor (left plan)		
Living & dining area	4.4 x 8.1m	14.4 x 26.6ft
Kitchen	3.7 x 2.9m	12.1 x 9.5ft
Terrace area	9.1 sq m	98.0 sq ft
Lower ground floor (right plan)		
Master bedroom	4.4 x 4.2m	14.4 x 13.6ft
Bedroom two	3.3 x 3.9m	10.8 x 12.8ft
Bedroom three	4.4 x 3.9m	14.4 x 12.8ft
Ceiling height up to 3.6m on lower floor		

Floor areas are approximate.
Plans and specifications are for indicative purposes only.
Dashed area indicate approximate skylight area.

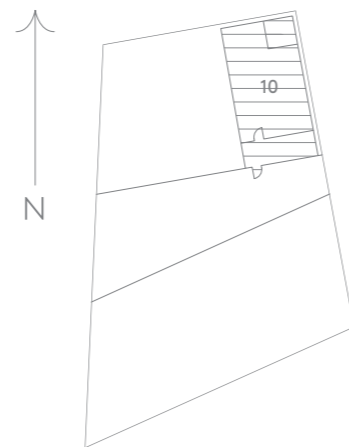

Kitchen

- Kitchen cabinetry and hardware custom-designed and unique to the development
- Quartzite natural stone worktop
- Mirrored backsplash with a bronze tint
- White ceramic under-mount sink
- Designer single lever tap
- Siemens dishwasher
- Liebherr fridge freezer
- Miele induction hob
- Miele PureLine microwave/oven combi
- Miele PureLine single oven

Interior finishes

- Engineered oak parquet flooring in a herringbone pattern to living, kitchen and dining areas
- Engineered oak plank flooring laid in bedrooms, hall and WC
- Custom-designed, integrated wardrobes to all bedrooms
- Siemens washing machine and separate condenser dryer
- Custom-designed ironmongery with brass rose and European oak wood handle

Bathrooms

- Bathroom tiling: Calacatta Viola marble flooring and white matt ceramic wall tile laid in a herringbone pattern with tile skirting boards
- Bathroom fittings: ceramic pedestal basin, antique gold basin tap, wall-mounted mirror cabinet with lighting, antique gold towel warmer, classic back-to-wall toilet and inset bath with antique gold shower and bath fixtures
- Master en-suite tiling: custom-designed marble flooring in a mosaic pattern and white marble walls
- Master en-suite fittings: ceramic basin on antique gold console, antique gold basin tap, wall-mounted mirror cabinet with lighting, antique gold towel warmer, classic back-to-wall toilet and shower with antique gold fixtures
- WC finish: engineered oak plank flooring and designer wallpaper
- WC fittings: ceramic basin on antique gold console, antique gold basin tap, wall-mounted mirror, classic back-to-wall toilet and decorative lighting

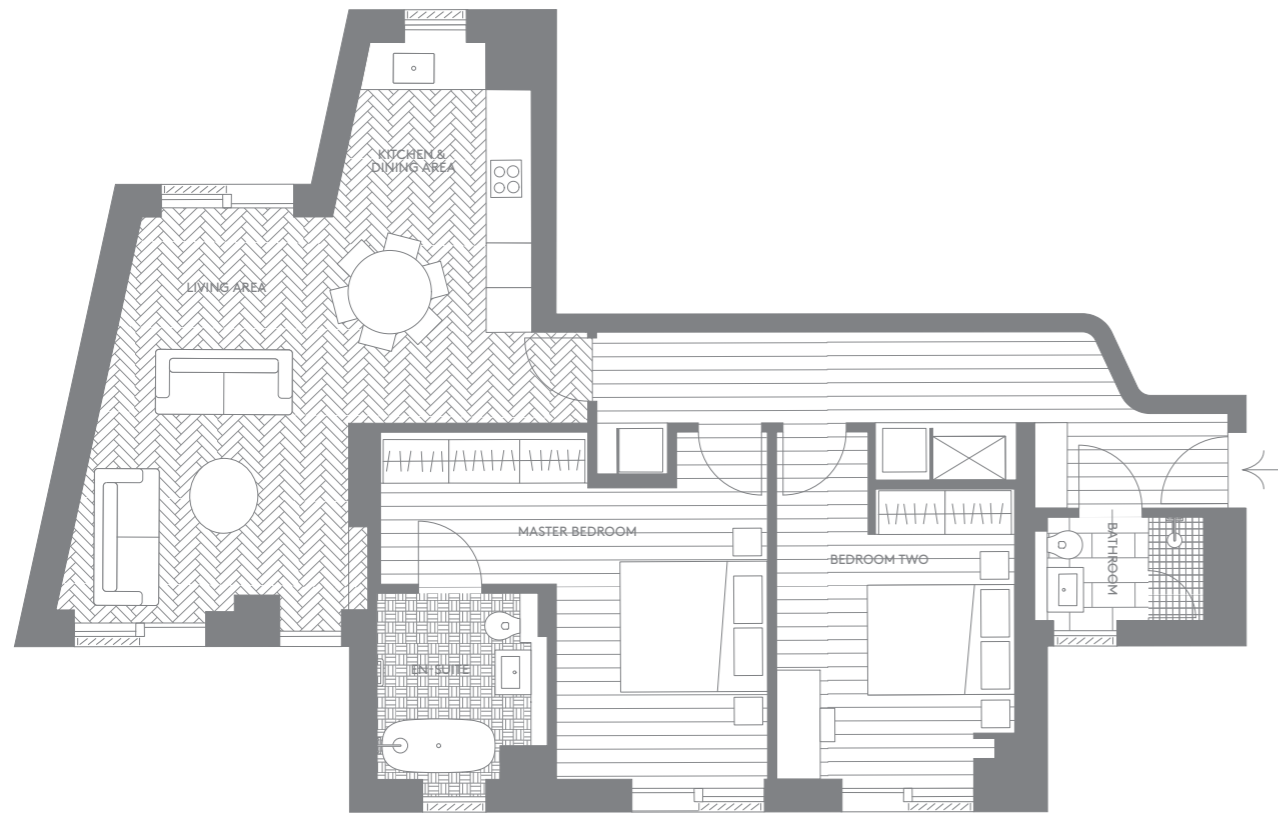

THE STATION HOUSE

Apartment 11, first floor

Two bedrooms

Internal area	95 sq m	1028 sq ft
Kitchen & dining area	3.5 x 5.2m	11.5 x 17.1ft
Living area	4.3 x 5.7m	14.1 x 18.7ft
Master bedroom	5.3 x 4.9m	17.4 x 16.1ft
Bedroom two	3.3 x 4.9m	10.8 x 16.1ft

Floor areas are approximate.
Plans and specifications are for indicative purposes only.

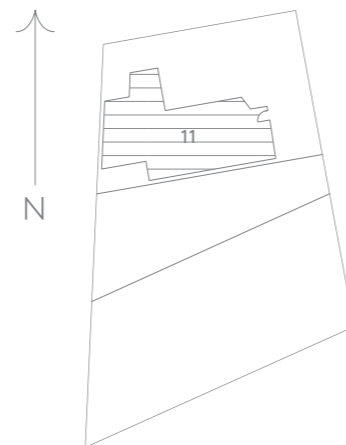

Kitchen

- Kitchen cabinetry and hardware custom-designed and unique to the development
- Quartzite natural stone worktop
- Mirrored backsplash with a bronze tint
- White ceramic under-mount sink
- Designer single lever tap
- Miele dishwasher
- Liebherr fridge freezer
- Miele induction hob
- Miele PureLine microwave/oven combi
- Miele PureLine single oven

Interior finishes

- Engineered oak parquet flooring in a herringbone pattern to living, kitchen and dining areas
- Engineered oak plank flooring laid in bedrooms and hall
- Custom-designed, integrated wardrobes to all bedrooms
- Siemens washing machine and separate condenser dryer
- Custom-designed ironmongery with brass rose and European oak wood handle

Bathrooms

- Bathroom tiling: Calacatta Viola marble flooring and white matt ceramic wall tile laid in a herringbone pattern with tile skirting boards
- Bathroom fittings: ceramic pedestal basin, antique gold basin tap, wall-mounted mirror cabinet with lighting, antique gold towel warmer, classic back-to-wall toilet and shower with antique gold fixtures
- Master en-suite tiling: custom-designed marble flooring in a mosaic pattern and white marble walls
- Master en-suite fittings: ceramic basin on antique gold console, antique gold basin tap, wall-mounted mirror cabinet with lighting, antique gold towel warmer, classic back-to-wall toilet and free-standing bath with antique gold fixtures

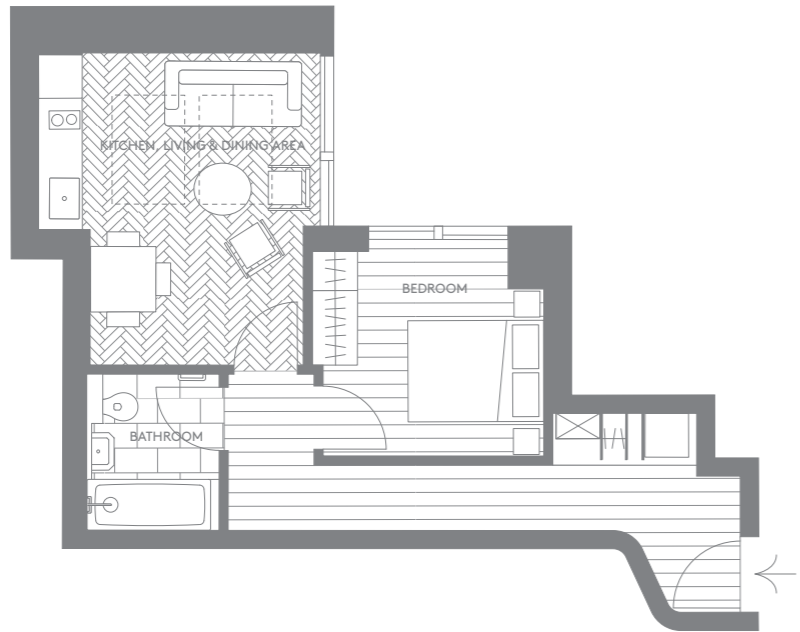

THE STATION HOUSE
 Apartment 12, first floor
One bedroom

Internal area	40 sq m	435 sq ft
Kitchen, living & dining area	3.9 x 4.3m	12.8 x 14.1ft
Bedroom	3.2 x 3.0m	10.5 x 9.8ft

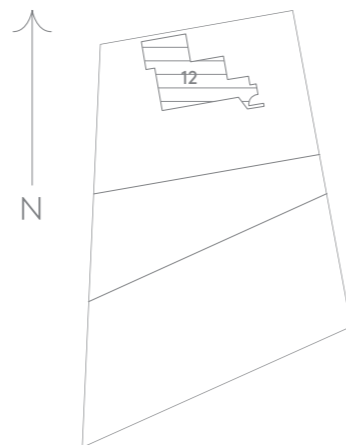

Floor areas are approximate.
 Plans and specifications are for indicative purposes only.
 Dashed area indicate approximate skylight areas.

- Kitchen**
- Kitchen cabinetry and hardware custom-designed and unique to the development
 - Quartzite natural stone worktop
 - Mirrored backsplash with a bronze tint
 - White ceramic under-mount sink
 - Designer single lever tap
 - Siemens dishwasher
 - Neff small fridge with freezer section
 - Miele two-burner induction hob
 - Miele PureLine single oven

- Interior finishes**
- Engineered oak parquet flooring in a herringbone pattern to living, kitchen and dining areas
 - Engineered oak plank flooring laid in bedroom and hall
 - Custom-designed, integrated wardrobes in bedroom
 - Siemens washing machine and dryer combo
 - Custom-designed ironmongery with brass rose and European oak wood handle

- Bathroom**
- Bathroom tiling: Calacatta Viola marble flooring and white matt ceramic wall tile laid in a herringbone pattern with tile skirting boards
 - Bathroom fittings: ceramic pedestal basin, antique gold basin tap, wall-mounted mirror cabinet with lighting, antique gold towel warmer, classic back-to-wall toilet and inset bath with antique gold shower and bath fixtures

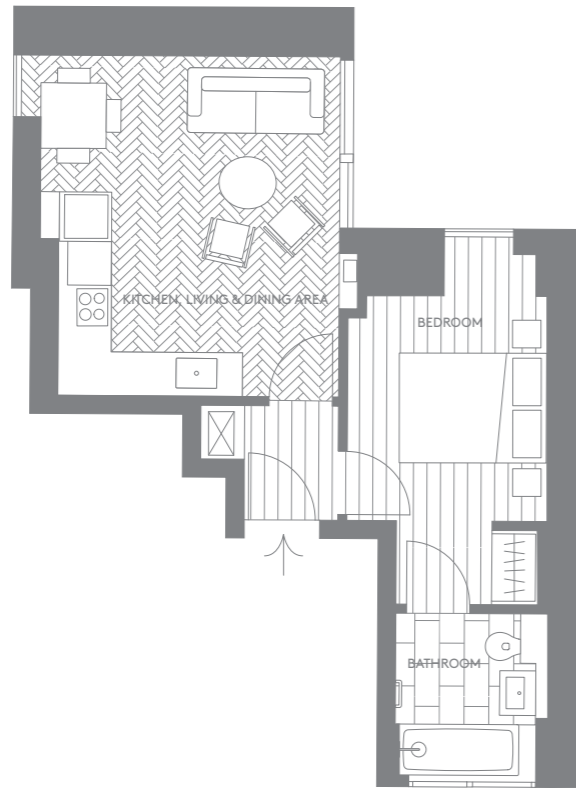

THE STATION HOUSE
 Apartment 14, first floor
One bedroom

Internal area	39 sq m	421 sq ft
Kitchen, living & dining area	4.1 x 4.7m	13.5 x 15.4ft
Bedroom	2.7 x 4.8m	8.9 x 15.7ft

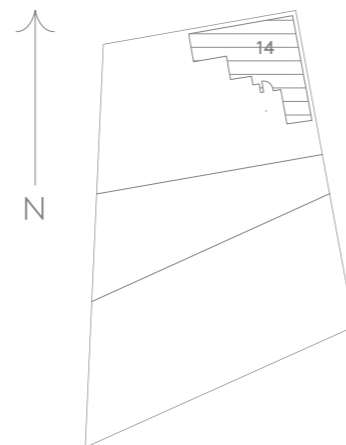

- Kitchen**
- Kitchen cabinetry and hardware custom-designed and unique to the development
 - Quartzite natural stone worktop
 - Mirrored backsplash with a bronze tint
 - White ceramic under-mount sink
 - Designer single lever tap
 - Siemens dishwasher
 - Liebherr fridge freezer
 - Miele induction hob
 - Miele PureLine single oven

- Bathroom**
- Bathroom tiling: Calacatta Viola marble flooring and white matt ceramic wall tile laid in a herringbone pattern with tile skirting boards
 - Bathroom fittings: ceramic basin on antique gold console, antique gold basin tap, wall-mounted mirror cabinet with lighting, antique gold towel warmer, classic back-to-wall toilet and shower with antique gold fixtures

- Interior finishes**
- Engineered oak parquet flooring in a herringbone pattern to living, kitchen and dining areas
 - Engineered oak plank flooring laid in bedroom and hall
 - Custom-designed, integrated wardrobes in bedroom
 - Siemens washing machine and dryer combo
 - Custom-designed ironmongery with brass rose and European oak wood handle

Floor areas are approximate.
 Plans and specifications are for indicative purposes only.

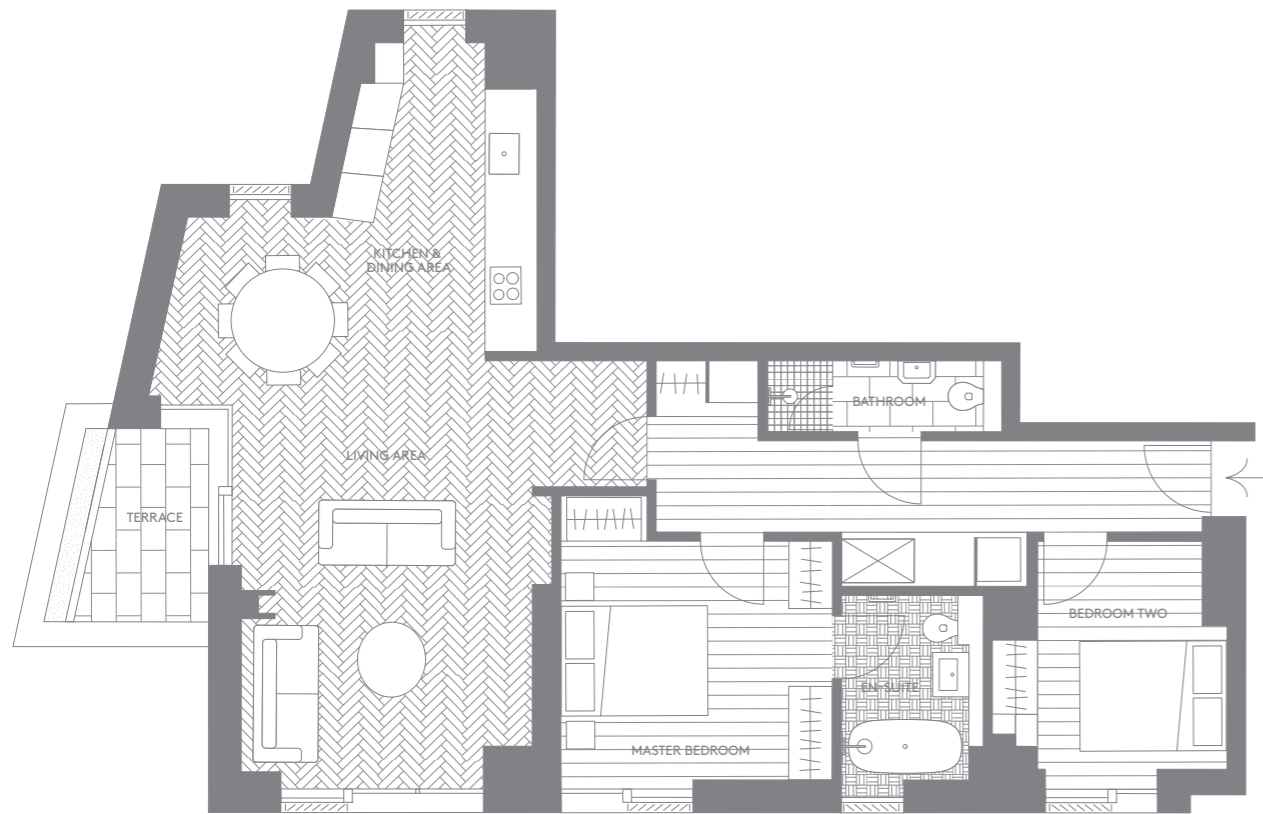

THE STATION HOUSE
 Apartment 15, second floor
Two bedrooms

Internal area	92 sq m	994 sq ft
Kitchen & dining area	4.6 x 5.0m	15.1 x 16.4ft
Living area	5.7 x 5.3m	18.7 x 17.4ft
Master bedroom	3.7 x 4.0m	12.1 x 13.1ft
Bedroom two	3.2 x 3.4m	10.5 x 11.2ft
Terrace area	5.7 sq m	61.4 sq ft

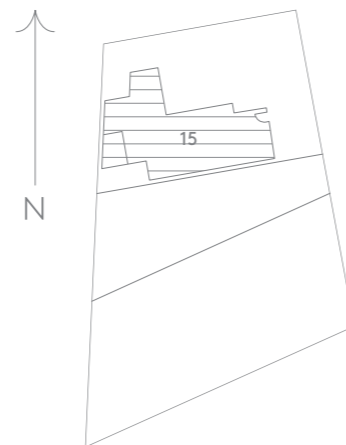

Floor areas are approximate.
 Plans and specifications are for indicative purposes only.

- Kitchen**
- Kitchen cabinetry and hardware custom-designed and unique to the development
 - Quartzite natural stone worktop
 - Mirrored backsplash with a bronze tint
 - White ceramic under-mount sink
 - Designer single lever tap
 - Siemens dishwasher
 - Liebherr fridge freezer
 - Miele induction hob
 - Miele PureLine microwave/oven combi
 - Miele PureLine single oven

- Interior finishes**
- Engineered oak parquet flooring in a herringbone pattern to living, kitchen and dining areas
 - Engineered oak plank flooring laid in bedrooms and hall
 - Custom-designed, integrated wardrobes to all bedrooms
 - Siemens washing machine and separate condenser dryer
 - Custom-designed ironmongery with brass rose and European oak wood handle

- Bathrooms**
- Bathroom tiling: Calacatta Viola marble flooring and white matt ceramic wall tile laid in a herringbone pattern with tile skirting boards
 - Bathroom fittings: ceramic basin on antique gold consoles, antique gold basin tap, wall-mounted mirror cabinet with lighting, antique gold towel warmer, classic back-to-wall toilet and shower with antique gold fixtures
 - Master en-suite tiling: custom-designed marble flooring in a mosaic pattern and white marble walls
 - Master en-suite fittings: ceramic basin on antique gold console, antique gold basin tap, wall-mounted mirror cabinet with lighting, antique gold towel warmer, classic back-to-wall toilet and free-standing bath with antique gold shower and bath fixtures

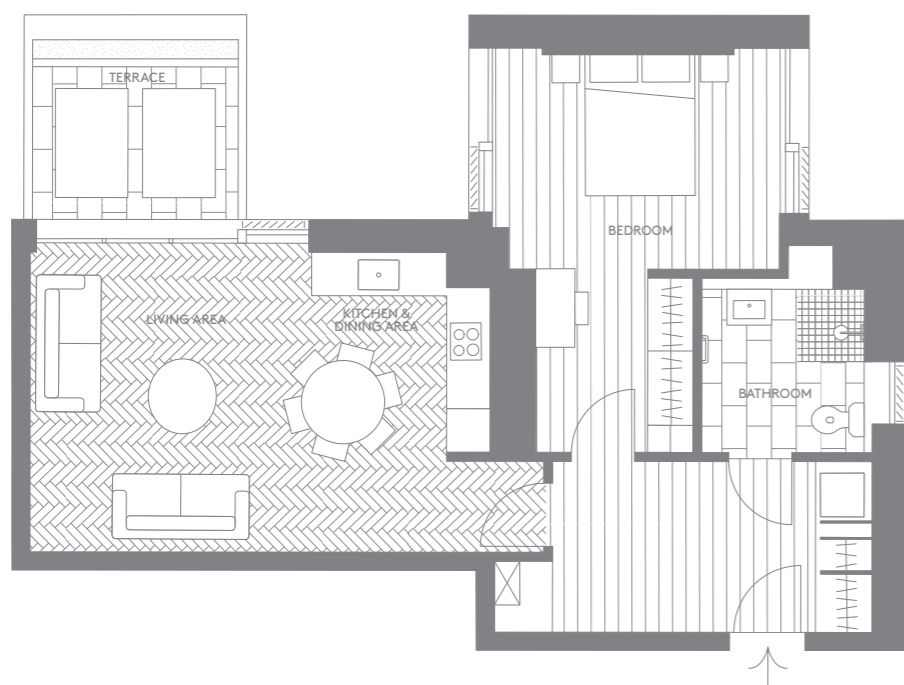

THE STATION HOUSE
 Apartment 16, second floor
One bedroom

Internal area	65 sq m	699 sq ft
Kitchen & dining area	3.3 x 4.1m	10.8 x 13.5ft
Living area	3.8 x 4.3m	12.5 x 14.1ft
Bedroom	4.0 x 5.6m	13.1 x 18.4ft
Terrace area	7.3 sq m	78.6 sq ft

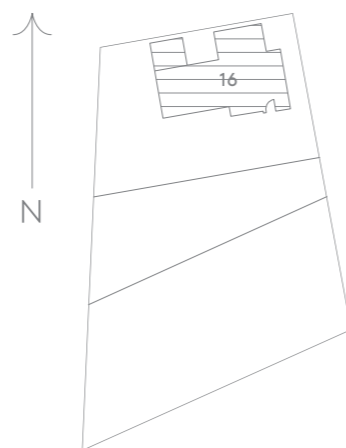

Kitchen

- Kitchen cabinetry and hardware custom-designed and unique to the development
- Quartzite natural stone worktop
- Mirrored backsplash with a bronze tint
- White ceramic under-mount sink
- Designer single lever tap
- Siemens dishwasher
- Liebherr fridge freezer
- Miele induction hob
- Miele PureLine single oven

Bathroom

- Bathroom tiling: Calacatta Viola marble flooring and white matt ceramic wall tile laid in a herringbone pattern with tile skirting boards
- Bathroom fittings: ceramic pedestal basin, antique gold basin tap, wall-mounted mirror cabinet with lighting, antique gold towel warmer, classic closed coupled toilet and shower with antique gold fixtures

Interior finishes

- Engineered oak parquet flooring in a herringbone pattern to living, kitchen and dining areas
- Engineered oak plank flooring laid in bedroom and hall
- Custom-designed, integrated wardrobes in bedroom
- Siemens washing machine and separate condenser dryer
- Custom-designed ironmongery with brass rose and European oak wood handle

Floor areas are approximate.
 Plans and specifications are for indicative purposes only.

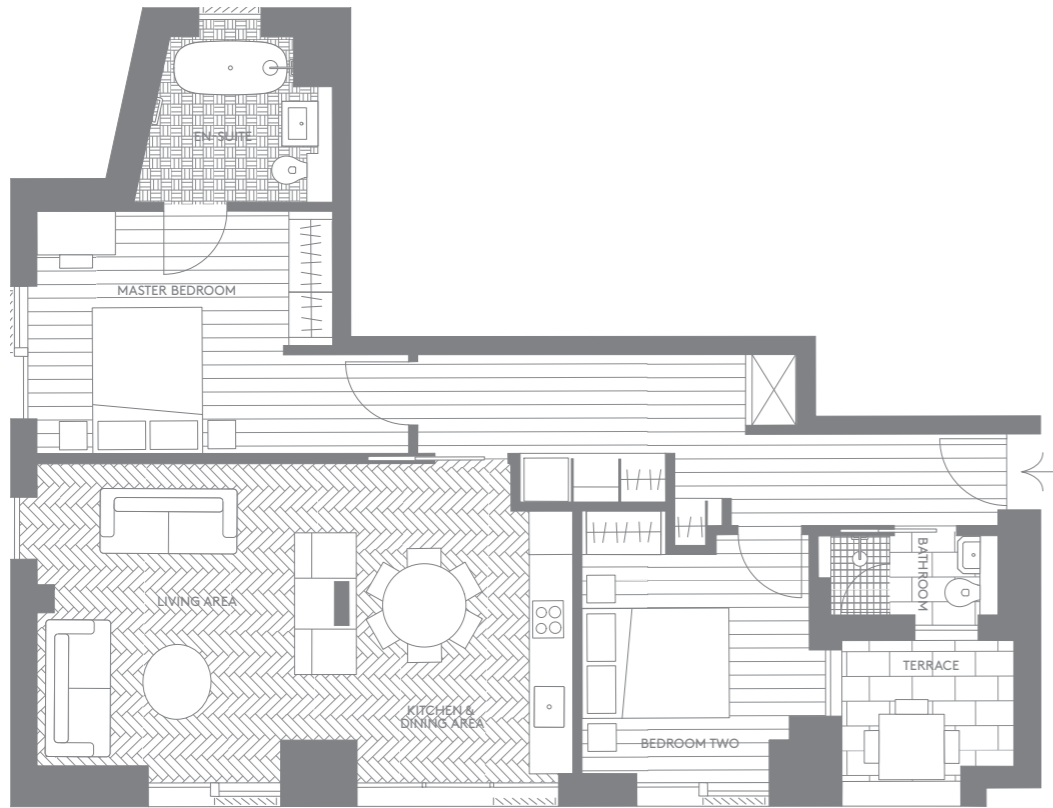

THE STATION HOUSE
 Apartment 17, third floor
Two bedrooms

Internal area	83 sq m	894 sq ft
Kitchen & dining area	2.9 x 4.4 m	9.5 x 14.4ft
Living area	4.4 x 4.4 m	14.4 x 14.4ft
Master bedroom	5.2 x 3.3 m	17.1 x 10.8ft
Bedroom two	3.1 x 3.6 m	10.2 x 11.8ft
Terrace area	4.3 sq m	46.0 sq ft

Floor areas are approximate.
 Plans and specifications are for indicative purposes only.

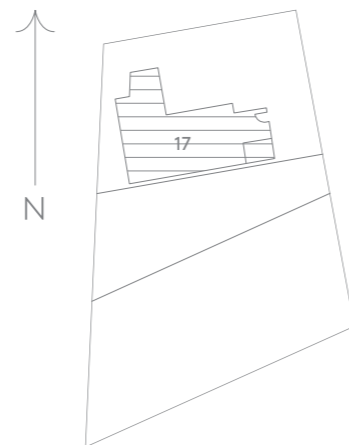

Kitchen

- Kitchen cabinetry and hardware custom-designed and unique to the development
- Quartzite natural stone worktop
- Mirrored backsplash with a bronze tint
- White ceramic under-mount sink
- Designer single lever tap
- Siemens dishwasher
- Liebherr fridge freezer
- Miele induction hob
- Miele PureLine single oven

Interior finishes

- Engineered oak parquet flooring in a herringbone pattern to living, kitchen and dining areas
- Engineered oak plank flooring laid in bedrooms and hall
- Custom-designed, integrated wardrobes to all bedrooms
- AEG washing machine and separate Miele condenser dryer
- Custom-designed ironmongery with brass rose and European oak wood handle

Bathrooms

- Bathroom tiling: Calacatta Viola marble flooring and white matt ceramic wall tile laid in a herringbone pattern with tile skirting boards
- Bathroom fittings: ceramic basin on antique gold console, antique gold basin tap, wall-mounted mirror cabinet with lighting, antique gold towel warmer, classic back-to-wall toilet and shower with antique gold fixtures
- Master en-suite tiling: custom-designed marble flooring in a mosaic pattern and white marble walls
- Master en-suite fittings: ceramic basin on antique gold console, antique gold basin tap, wall-mounted mirror cabinet with lighting, antique gold towel warmer, classic back-to-wall toilet and free-standing bath with antique gold shower and bath fixtures

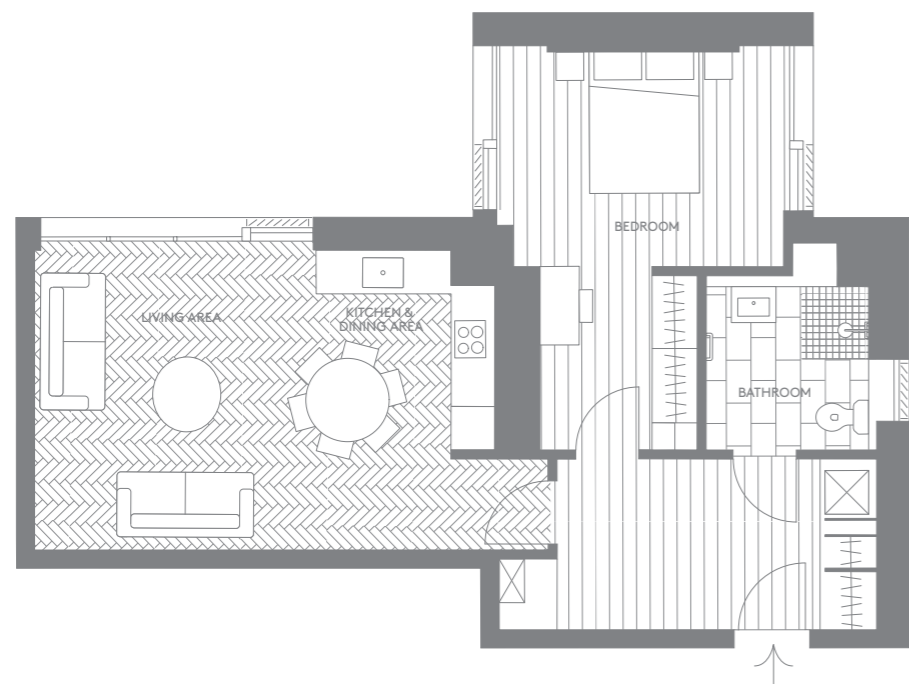

THE STATION HOUSE
 Apartment 18, third floor
One bedroom

Internal area	65 sq m	699 sq ft
Kitchen & dining area	3.3 x 4.1m	10.8 x 13.5ft
Living area	3.8 x 4.3m	12.5 x 14.1ft
Bedroom	4.0 x 5.6m	13.1 x 18.4ft

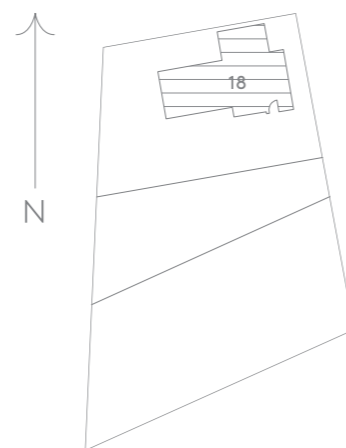

Kitchen

- Kitchen cabinetry and hardware custom-designed and unique to the development
- Quartzite natural stone worktop
- Mirrored backsplash with a bronze tint
- White ceramic under-mount sink
- Designer single lever tap
- Siemens dishwasher
- Liebherr fridge freezer
- Miele induction hob
- Miele PureLine single oven

Bathroom

- Bathroom tiling: Calacatta Viola marble flooring and white matt ceramic wall tile laid in a herringbone pattern with tile skirting boards
- Bathroom fittings: ceramic pedestal basin, antique gold basin tap, wall-mounted mirror cabinet with lighting, antique gold towel warmer, classic closed coupled toilet and shower with antique gold fixtures

Interior finishes

- Engineered oak parquet flooring in a herringbone pattern to living, kitchen and dining areas
- Engineered oak plank flooring laid in bedroom and hall
- Custom-designed, integrated wardrobes in bedroom
- Siemens washing machine and separate condenser dryer
- Custom-designed ironmongery with brass rose and European oak wood handle

Floor areas are approximate.
 Plans and specifications are for indicative purposes only.



THE STATION HOUSE
 Apartment 19, fourth floor
Three bedrooms

Internal area	118 sq m	1268 sq ft
Living & dining area	5.0 x 8.0m	16.4 x 26.2ft
Kitchen	2.3 x 4.3m	7.5 x 14.1ft
Master bedroom	4.3 x 5.2m	14.1 x 17.1ft
Bedroom two	4.2 x 3.7m	13.8 x 12.1ft
Bedroom three	3.4 x 3.7m	11.2 x 12.1ft
Terrace one area	9.9 sq m	106.6 sq ft
Terrace two area	21.0 sq m	226.0 sq ft
Terrace three area	6.8 sq m	73.2 sq ft

Floor areas are approximate.
 Plans and specifications are for indicative purposes only.

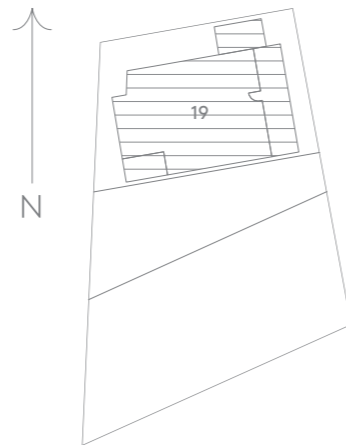

Kitchen

- Kitchen cabinetry and hardware custom-designed and unique to the development
- Quartzite natural stone worktop
- Mirrored backsplash with a bronze tint
- White ceramic under-mount sink
- Designer single lever tap
- Siemens dishwasher
- Liebherr fridge freezer
- Miele induction hob
- Miele PureLine microwave/oven combi
- Miele PureLine single oven

Interior finishes

- Engineered oak parquet flooring in a herringbone pattern to living, kitchen and dining areas
- Engineered oak plank flooring laid in bedrooms and hall
- Custom-designed, integrated wardrobes to all bedrooms
- Siemens washing machine and separate Miele condenser dryer
- Custom-designed ironmongery with brass rose and European oak wood handle

Bathrooms

- Bathroom tiling: Calacatta Viola marble flooring and white matt ceramic wall tile laid in a herringbone pattern with tile skirting boards
- Bathroom fittings: ceramic pedestal basin, antique gold basin tap, wall-mounted mirror cabinet with lighting, antique gold towel warmer, classic back-to-wall toilet and free-standing bath with antique gold bath fixtures and wet room shower with antique gold fixtures
- Master en-suite tiling: custom-designed marble flooring in a mosaic pattern and white marble walls
- Master en-suite fittings: ceramic basin on antique gold console, antique gold basin tap, wall-mounted mirror cabinet with lighting, antique gold towel warmer, classic back-to-wall toilet and shower with antique gold fixtures

The soul of the Fire Station has been maintained and modernised in both aesthetics and sustainability – honouring its history, while treading lightly on the environment. A timeless building, reinvented for the future.

This is complemented by the Station House, with its low-impact materiality, solar panels, and biodiverse green roof. Together, both buildings help Westminster Fire Station soar past environmental targets.



60

*% targeted
reduction
in carbon
emissions.**

Overall, the development has a carbon reduction of 60%* –exceeding the carbon reduction target of 35% set by the Greater London Authority and the City of Westminster. This is in large part due to the efforts that went into restoring the Fire Station.

From its earliest stages, the development has been handled responsibly and conscientiously. Even during construction, a site-wide management plan was adopted to promote resource efficiency. As a result, opportunities for recycling were identified, and a significant percentage of the buildings waste was saved from landfill. From the careful selection and transport of materials to the heat recovery units that provide fresh air and maintain air quality, the design team explored opportunities to provide sustainable features for the benefit of future residents.

*Subject to the final energy assessment being carried out post completion when outstanding information such as the air test results for each dwelling have been received.

The Fire Station

Keeping the Edwardian building played a crucial part in the sustainability of the development. A significant amount of embodied carbon has been saved by retaining and extending its original structure. If the station was built anew, the development would have created more greenhouse gas emissions from the processing, manufacturing, transporting and construction of materials.

As such, the design process has been centred on finding opportunities to enhance energy performance and efficiencies while retaining and elevating its characterful and historic fabric.





The Station House

The architecture of the Station House is meticulously designed to reduce heat loss in winter and use the sun's warmth in summer. It is designed to allow in as much daylight as possible, with the intention that less energy will be required for artificial lighting.

The interior specifications have been chosen for their quality and their low environmental impacts. Responsibly sourced materials and suppliers were sought, and local suppliers were prioritised to help minimise impact. The wood floors are FSC* and PEFC* certified and comply with EUTR* regulations. And for every tree harvested, at least three more are re-planted.

WRAS* approved low water use sanitaryware has been installed throughout to reduce consumption beyond the current building regulation targets. As a result, demand for domestic hot water has also been reduced, offering additional energy savings.

The building has a green roof of wildflowers, chosen for their biodiversity and grown in organic fertiliser. Not only does it offer a vibrant view from above, but it also improves air quality in the local microclimate.

**FSC - Forest Stewardship Council
*PEFC Programme for the Endorsement of Forest Certification
EUTR - European Union Timber Regulation

10%

Reduction in unregulated carbon emissions, by using energy-efficient appliances and user-friendly energy measuring thermostats.

60%

Targeted reduction in carbon emissions.*

80%

Of waste heat saved by heat recovery units.

2.9

Tonnes of carbon saved per year by using solar panels.

CHRISTIE'S

INTERNATIONAL REAL ESTATE

— DUBAI —

DIFC | Dubai World Trade Centre | Business Bay

P.O. Box: 25129, Dubai, UAE, ORN 11814

+971 4 425 2780 | info@christiesrealestatedubai.com | www.christiesrealestatedubai.com